

# **AKKON CNC**

## **Hardware Connection**

Version 1.1  
2nd of January 2011

# AKKON ARM7 Controller Board

## PC, motor and main spindle connection

AKKON control unit case

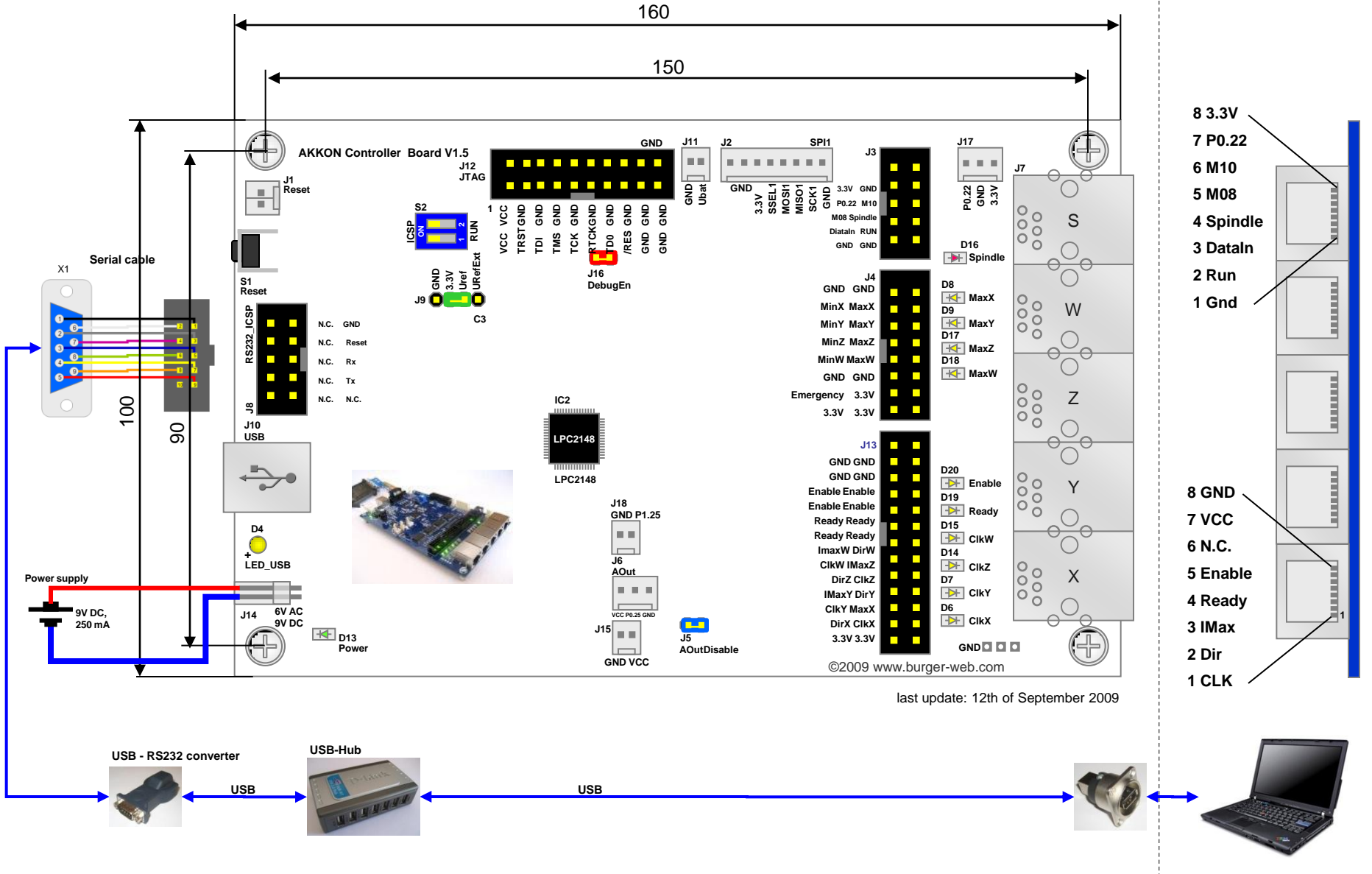

# AKKON ARM7 Controller Board

## Connection of limit switches

AKKON control unit case

AKKON Controller Board



J4

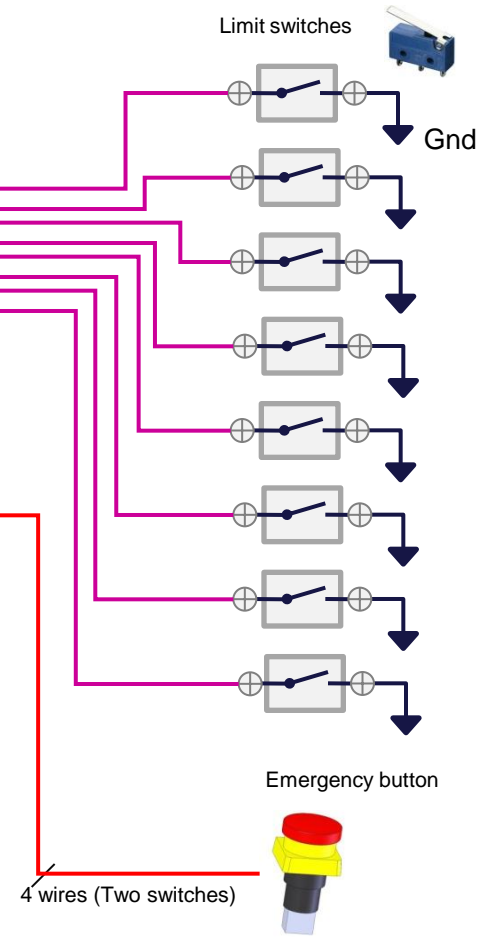
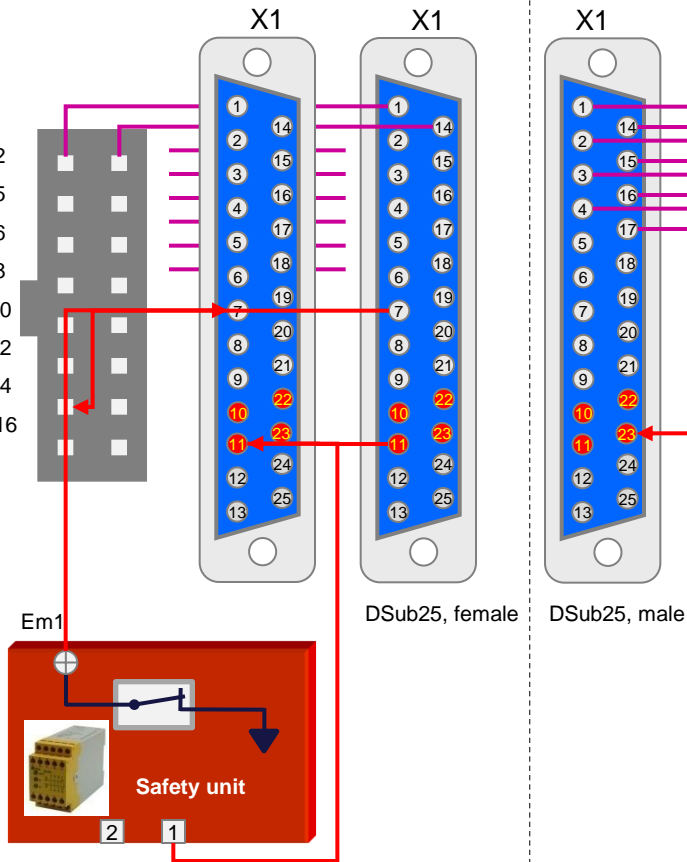
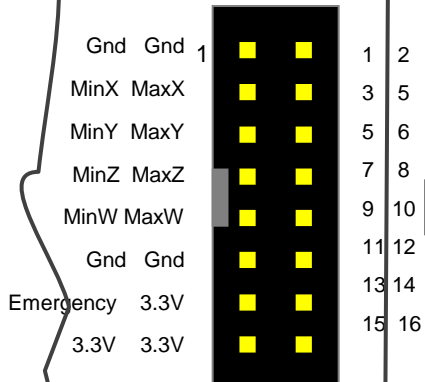

# AKKON ARM7 Controller Board

## Connection of Automatic Tool Measurement Switch

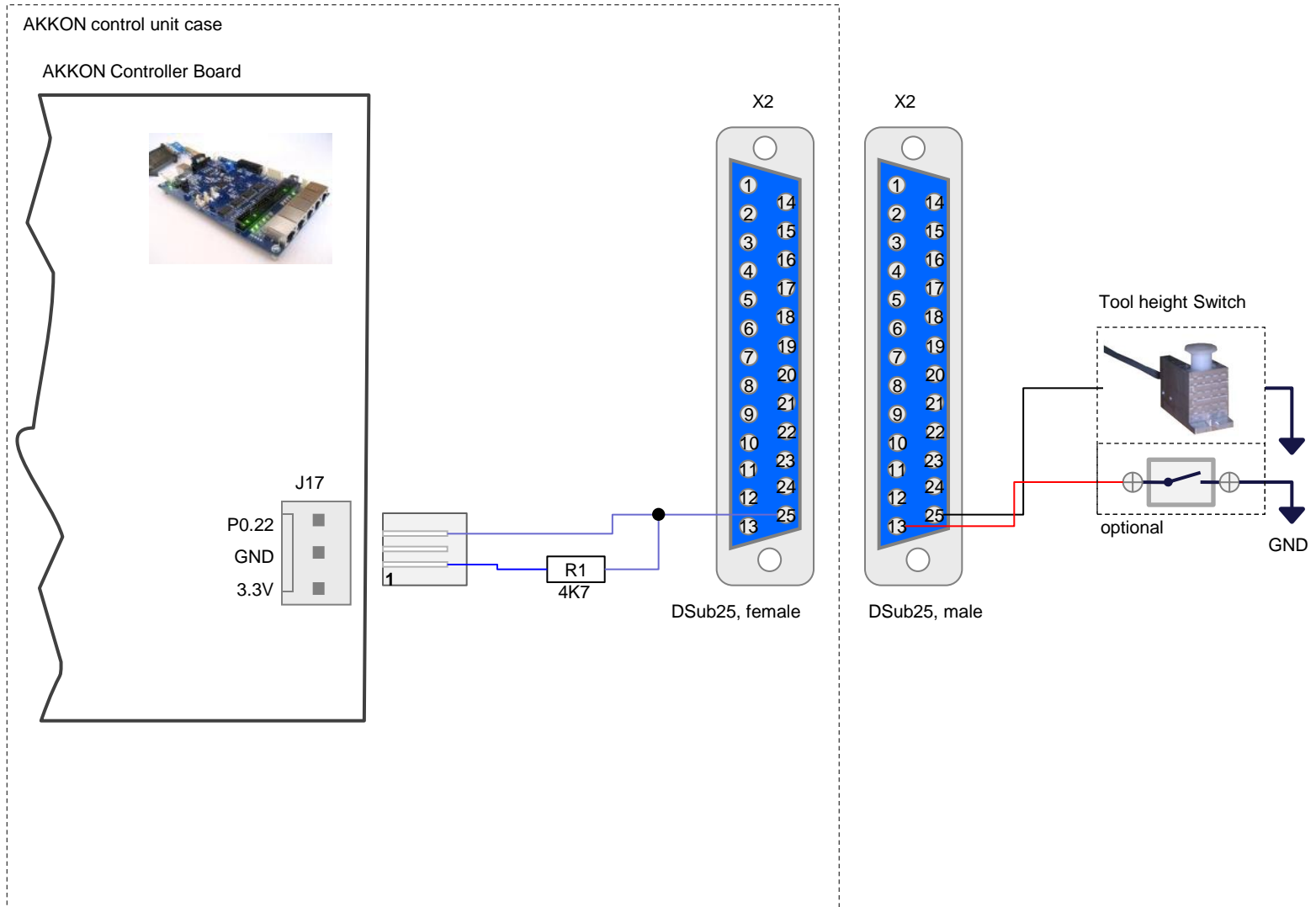

# AKKON ARM7 Controller Board

## Connection of AKKON Handwheel

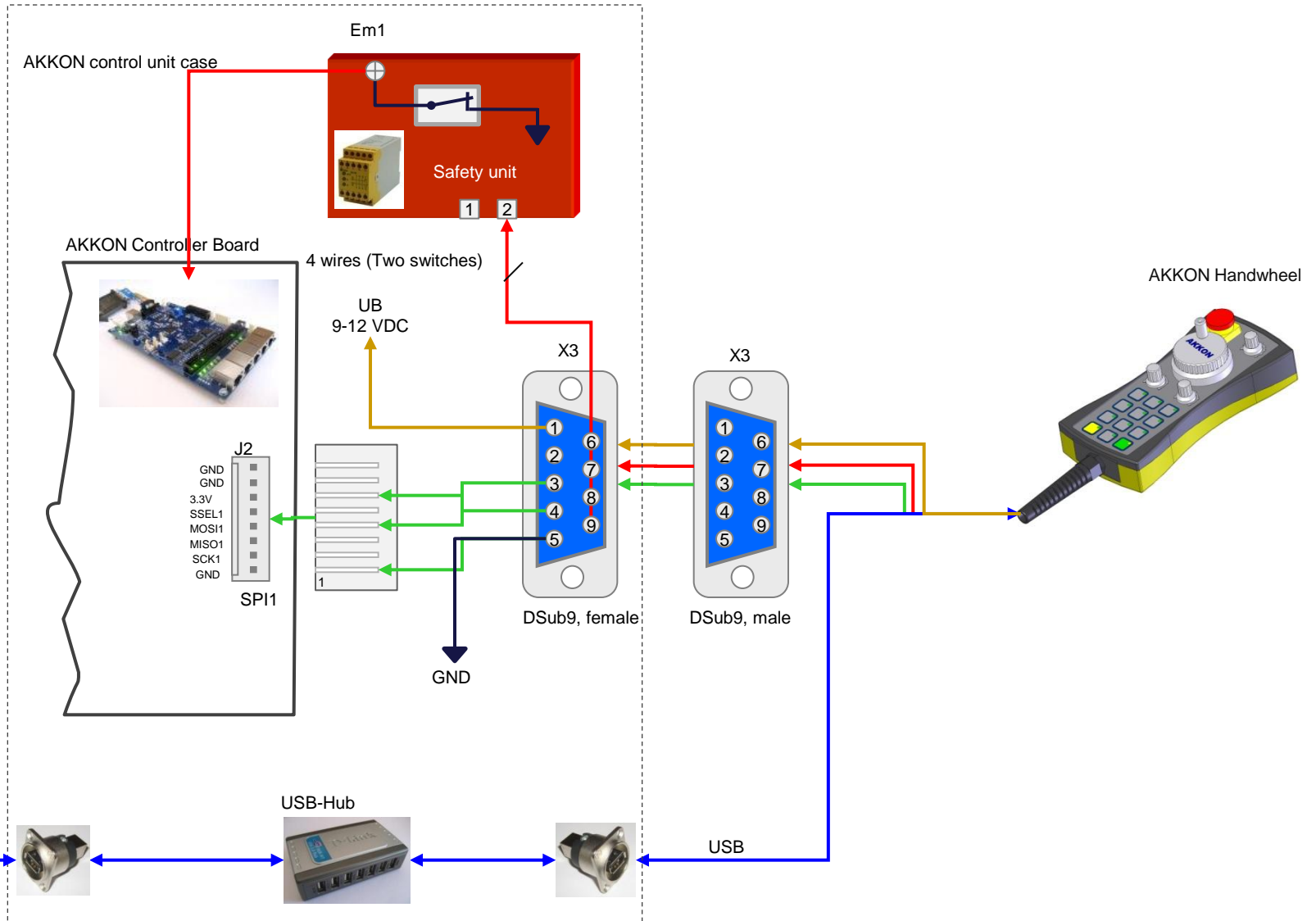

# AKKON ARM7 Controller Board

## Connection of auxiliary drives

AKKON control unit case

AKKON Controller Board



J3

3.3V GND  
P0.22 M10  
M08 Spindle  
DiataIn RUN  
GND GND

