

AKKON USB CONTROLLER BOARD

USB microcontroller board with the ARM7 LPC2148™*
Hardware test

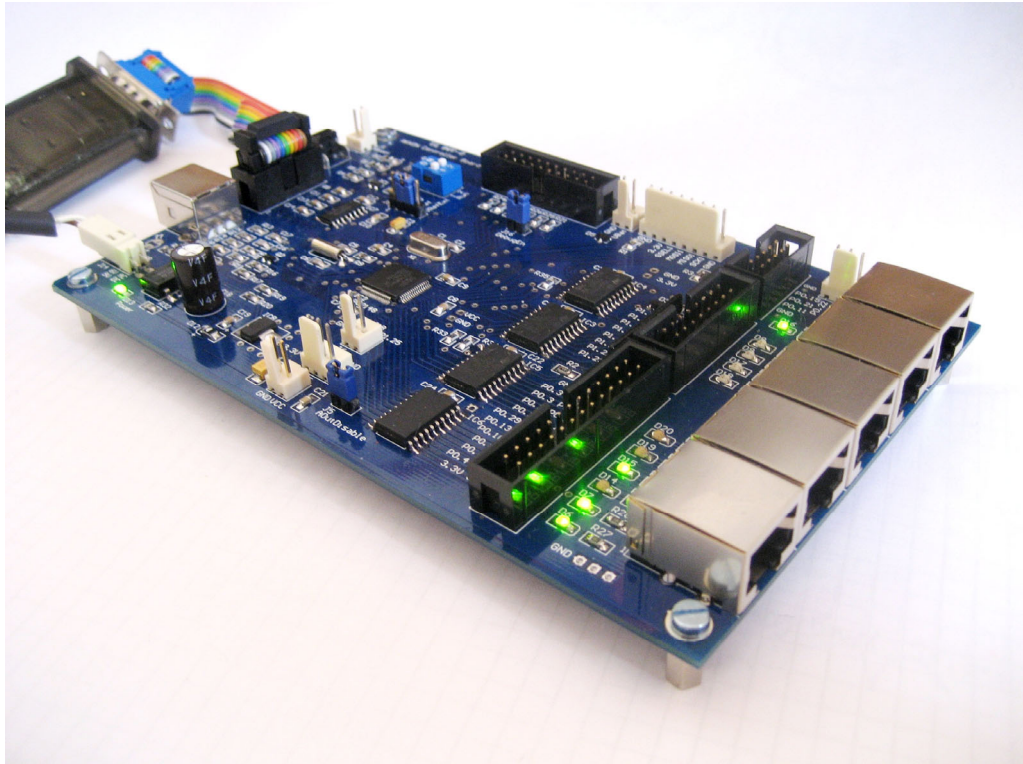

Authors: Gerhard Burger
 Version: 1.0
 Last update: 23.06.2008
 File: TN014_AKKON_USB_Controller_Board_RS232_Firmware_Update.doc
 Attachments: no attachments

Table of versions

Version	Date	Remarks
1.0	26.06.2008	first version

Table of versions 1

1 INTRODUCTION 3

2 TEST POINTS 3

3 TEST EXTERNAL RESET LOGIC 3

4 TEST POWER SUPPLY 4

5 TEST RS232 5

6 KNOWN PROBLEMS 5

7 DISCLAIMER 6

7.1 Limited Warranty and Disclaimer of Warranty 6

7.2 ACKNOWLEDGMENT 6

1 Introduction

The AKKON USB Controller Board is a prototyping or development board based on the LPC2148 ARM7 micro controller, with USB support, power supply and IO drivers. The board is designed as development kit for starting up working with ARM7 microcontrollers and for fast development of new devices.

This document outlines some easy hardware tests for startup after construction the board or for troubleshooting purposes.

2 Test points

Performing the hardware test a Digital Multi Meter (DMM) is necessary. Following figure shows the mounting plan of the AKKON USB Controller Board and some test points, displayed as yellow balloons. Each test point has at least a name, a value and a unit of measurement.

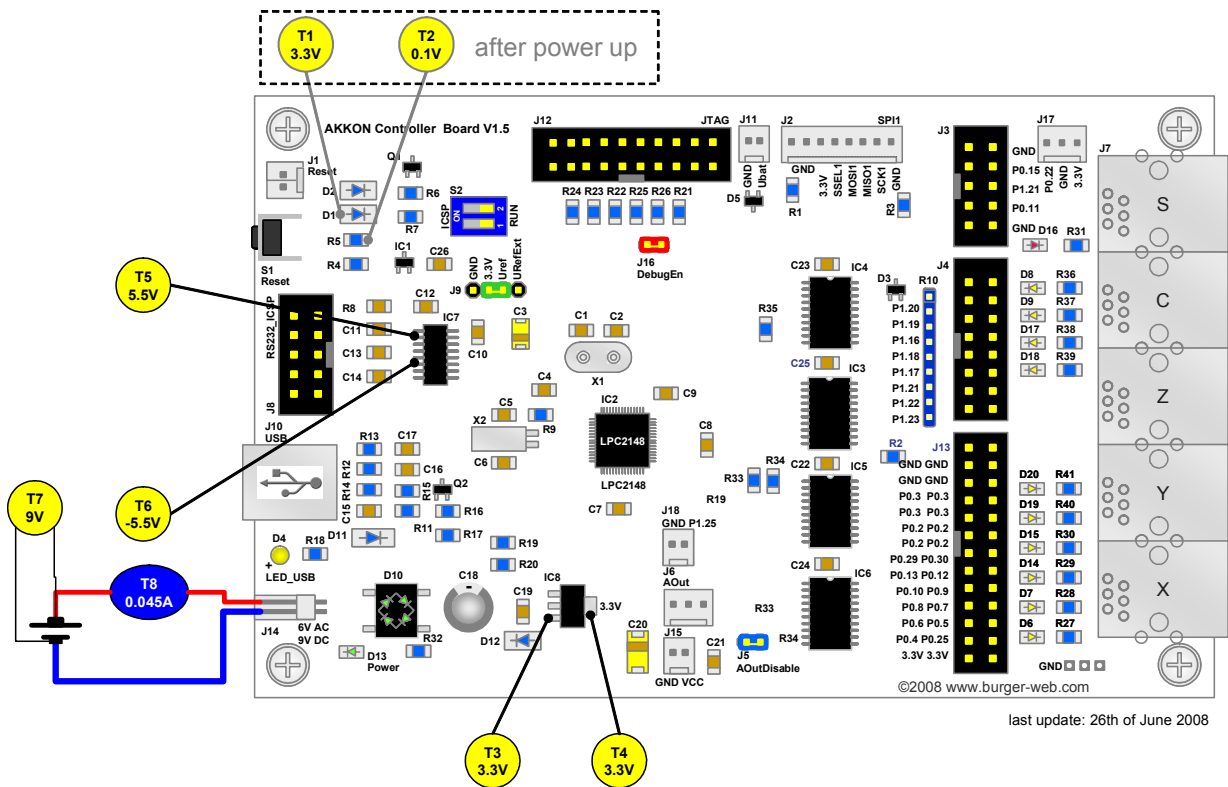

Figure 1: Mounting plan of AKKON USB Controller Board and hardware test points

3 Test external Reset Logic

1. Download free Bray terminal program (GOOGLE search : **download bray terminal**)
2. Connect AKKON USB Controller Board with serial cable or USB to RS232-converter
3. Start Bray terminal program
4. Set digital multi meter to voltage measurement mode and connect Ground to GND of AKKON USB Controller Board.

5. Set second test pin to Anode of D2
6. Connect serial port and switch on DTR signal by pressing the DTR toggle button (see red balloon on following picture)

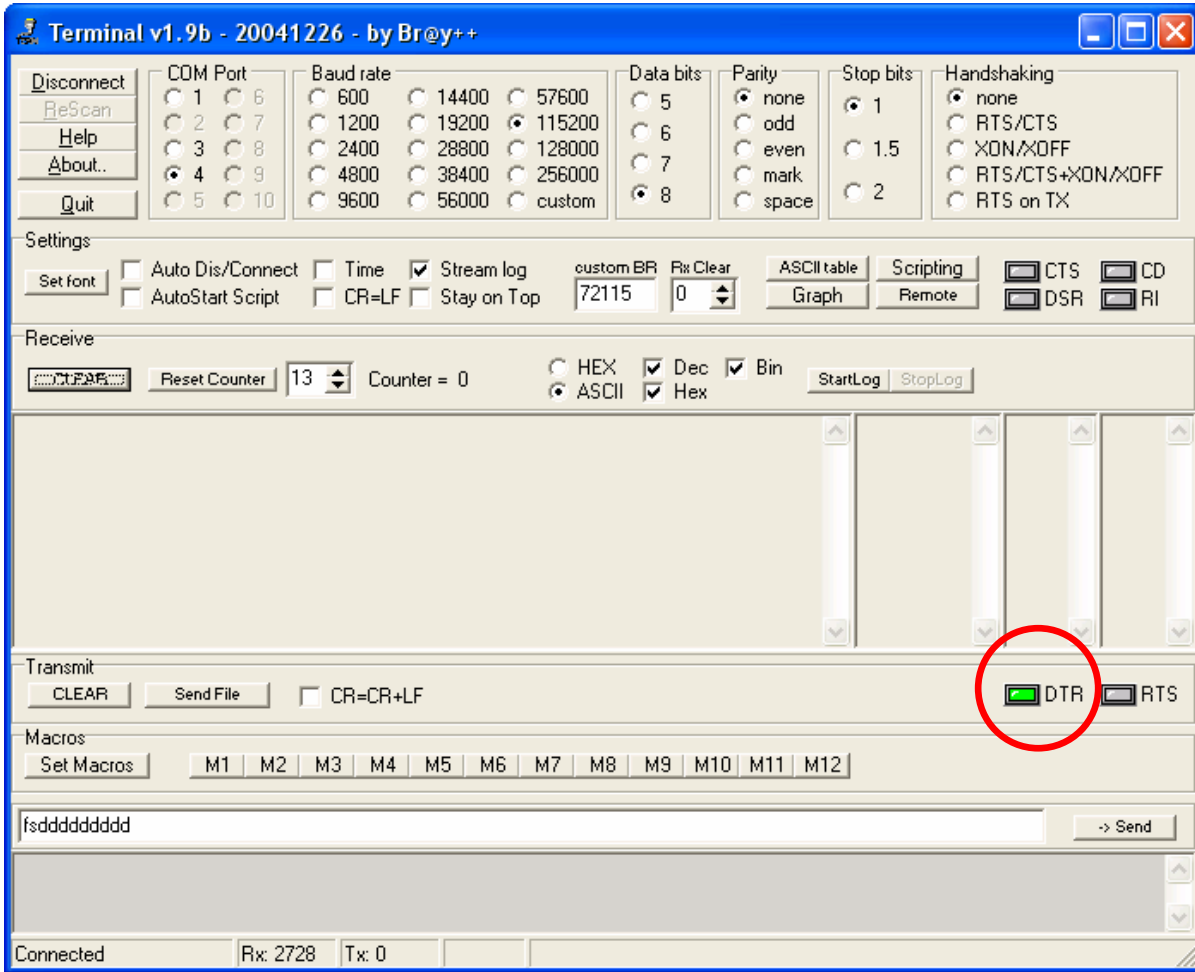

Figure 2: Terminal program with option for manual setting or DTR-signal

Result of measurement:

Pos	DTR	Voltage on Anode of D1 [V]
1	On	0
2	Off	3.3V

Figure 3: Hardware test points of external reset logic

4 Test Power supply

- Upload AKKON CNC Controller Firmware to the AKKON USB Controller Board
- Disconnect all external devices from the board
- Set external input voltage of AKKON USB Controller Board to 9 Volt direct current.
- Perform voltage measurement (T7) It should be 9V

- Perform current measurement (T8). The current should not exceed 100mA. A test of AKKON USB Controller Board has shown that the value is about 50mA
- Perform voltage measurement on IC8 (set Ground of Multi Meter to the GND-pin of the AKKON USB Controller Board)

Pos	IC	Pin	UMeasurement [V]
1	8	1	2
2	8	2	3.3
3	8	3	7.4
4	8	4	3.3

Figure 4: Hardware test points of power supply

Voltage on Pin 3 depends on the voltage of input pin, also the one of Pin 1.

5 Test RS232

Performing this hardware test, the AKKON USB Controller Board has to be powered up and the serial cable is **not** connected.

Pos	IC7	Pin	Umeasurement [V]
1	7	1	3.3
2	7	2	5.5
3	7	3	6.0
4	7	4	5.8
5	7	5	0.3
6	7	6	-5.5
7	7	7	6.1
8	7	8	0.0
9	7	9	3.3
10	7	10	0.0
11	7	11	1.1
12	7	12	3.3
13	7	13	7.8
14	7	14	5.5
15	7	15	0.0
16	7	16	3.3

Figure 5: Hardware test points of RS232

6 Known problems

- Serial adapter cable has wrong pin IO
- Switch S2 is in wrong position. This situation can also be if switch S2 is has been mirrored soldered in
- Power supply not connected to the board or board is not enough powered
- Some parts have not be soldered or quality of soldering is poor

7 Disclaimer

7.1 *Limited Warranty and Disclaimer of Warranty*

THIS SOFTWARE AND ACCOMPANYING WRITTEN MATERIALS (INCLUDING INSTRUCTIONS FOR USE) ARE PROVIDED "AS IS" WITHOUT WARRANTY OF ANY KIND. FURTHER, the author DOES NOT WARRANT, GUARANTEE, OR MAKE ANY REPRESENTATIONS REGARDING THE USE, OR THE RESULTS OF USE, OF THE SOFTWARE OR WRITTEN MATERIALS IN TERMS OF CORRECTNESS, ACCURACY, RELIABILITY, CURRENTNESS, OR OTHERWISE. THE ENTIRE RISK AS TO THE RESULTS AND PERFORMANCE OF THE SOFTWARE IS ASSUMED BY YOU. IF THE SOFTWARE OR WRITTEN MATERIALS ARE DEFECTIVE YOU, AND NOT the author OR ITS DEALERS, DISTRIBUTORS, AGENTS, OR EMPLOYEES, ASSUME THE ENTIRE COST OF ALL NECESSARY SERVICING, REPAIR, OR CORRECTION.

THE ABOVE IS THE ONLY WARRANTY OF ANY KIND, EITHER EXPRESS OR IMPLIED, INCLUDING BUT NOT LIMITED TO THE IMPLIED WARRANTIES OF MERCHANTABILITY AND FITNESS FOR A PARTICULAR PURPOSE, THAT IS MADE BY the author, ON THIS PRODUCT. NO ORAL OR WRITTEN INFORMATION OR ADVICE GIVEN BY the author, ITS DEALERS, DISTRIBUTORS, AGENTS OR EMPLOYEES SHALL CREATE A WARRANTY OR IN ANY WAY INCREASE THE SCOPE OF THIS WARRANTY AND YOU MAY NOT RELY ON ANY SUCH INFORMATION OR ADVICE.

NEITHER the author NOR ANYONE ELSE WHO HAS BEEN INVOLVED IN THE CREATION, PRODUCTION OR DELIVERY OF THIS PRODUCT SHALL BE LIABLE FOR ANY DIRECT, INDIRECT, CONSEQUENTIAL OR INCIDENTAL DAMAGES (INCLUDING DAMAGES FOR LOSS OF BUSINESS PROFITS, BUSINESS INTERRUPTION, LOSS OF BUSINESS INFORMATION, AND THE LIKE) ARISING OUT OF THE USE OR INABILITY TO USE SUCH PRODUCT EVEN IF the author HAS BEEN ADVISED OF THE POSSIBILITY OF SUCH DAMAGES.

7.2 **ACKNOWLEDGMENT**

BY USING THIS PRODUCT YOU ACKNOWLEDGE THAT YOU HAVE READ THIS LIMITED WARRANTY, UNDERSTAND IT, AND AGREE TO BE BOUND BY ITS' TERMS AND CONDITIONS. YOU ALSO AGREE THAT THE LIMITED WARRANTY IS THE COMPLETE AND EXCLUSIVE STATEMENT OF AGREEMENT BETWEEN THE PARTIES AND SUPERSEDE ALL PROPOSALS OR PRIOR AGREEMENTS, ORAL OR WRITTEN, AND ANY OTHER COMMUNICATIONS BETWEEN THE PARTIES RELATING TO THE SUBJECT MATTER OF THE LIMITED WARRANTY.